

**ADJUSTABLE CUTTERHEAD 4-7,5MM WITH REVERSIBLE KNIVES FOR GROOVES (Z=4 + V=4)
BORE 50MM - Ø160MM**

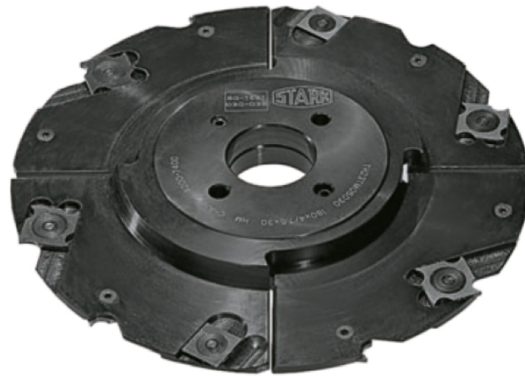

€297,52 (excl. VAT)

Adjustable cutterhead with reversible knives in high quality carbide metal (HW) for making thin precision grooves. Adjustable in height between 4mm and 7.5mm by means of spacer rings. Spacer rings included as standard. Thanks to the tungsten carbide blades, this cutterhead cuts effortlessly through solid boards, hard and soft woods, MDF or laminated boards.

An additional spacer to mill grooves up to 15mm is available on request.

SKU: ST-TH23TM25

GALERIJAFBEELDINGEN

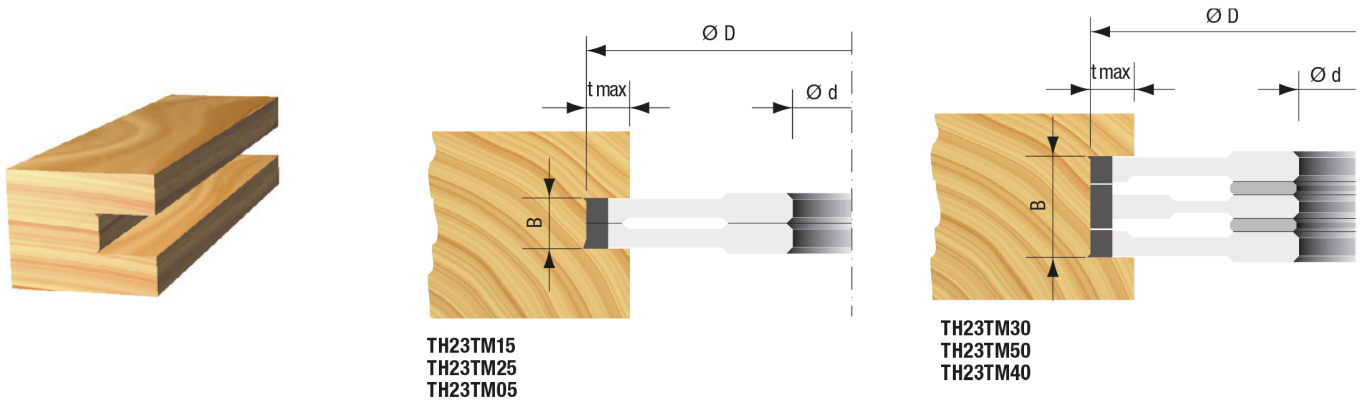

Adjustable cutterhead with reversible knives in high quality carbide metal (HW) for making thin precision grooves. Adjustable in height between 4mm and 7.5mm by means of spacer rings. Spacer rings included as standard. Thanks to the tungsten carbide blades, this cutterhead cuts effortlessly through solid boards, hard and soft woods, MDF or laminated boards.

An additional spacer to mill grooves up to 15mm is available on request.

PRODUCT INFORMATION

- For spindle moulder machines
- For making precision grooves and slots
 - For laminated panels or MDF
 - Hard and soft wood

DESCRIPTION

Adjustable cutterhead with reversible knives in high quality carbide metal (HW) for making thin precision grooves. Adjustable in height between 4mm and 7.5mm by means of spacer rings. Spacer rings included as standard. Thanks to the tungsten carbide blades, this cutterhead cuts effortlessly through solid boards, hard and soft woods, MDF or laminated boards. An additional spacer to mill grooves up to 15mm is available on

request.

No video available for this product!

DOWNLOADS

No download available.

ADDITIONAL INFORMATION

Weight	1 kg
diameter	160mm
Shaft diameter	50 mm
Cutting edges	4
Number of teeth	4
Cutting length	35mm
Height of groove	4-7,5mm
RPM Min-Max	4800-8200