

**TOOLING SET FOR ROUNDING AND CHAMFERING (Z=2+2+2) - Ø139MM**



**€487,60 - €512,39 (excl. VAT)**

Cutterset consisting of two elements in light alloy with reversible tungsten carbide knives (HW). Cutter set specifically designed to perform both high precision planing and chamfering. Suitable for machining wood with a height between 18mm and 50mm. The blades have a radius on the one hand and a chamfer of 45° on the other hand. The blades with radius R4 are mounted on the milling head as standard. Knives with radius R2, R3, R5 and R6 are available separately.

Because the knives are placed both above and below the cutterset, it is possible to round off/chamfer your workpiece in one passage. Thanks to the tungsten carbide blades, this profile cutter cuts effortlessly through solid boards or solid wood. Also suitable for use on sheet materials.

**SKU: N/A**

### VARIATIONS

Image	SKU	Description	Shaft diameter	Price
	ST-YS118AZM-50		50 mm	€512,39 (excl. VAT)
	ST-YS118AZM-30		30 mm	€487,60 (excl. VAT)

### GALERIJAFBEELDINGEN

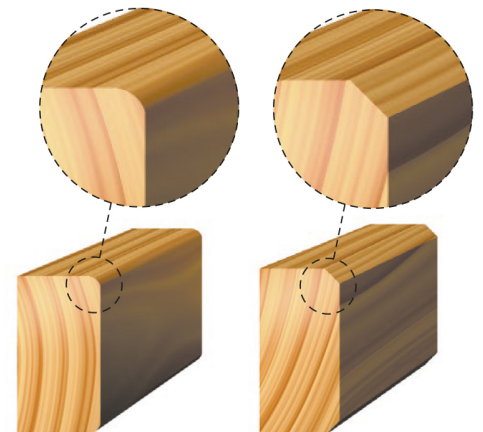
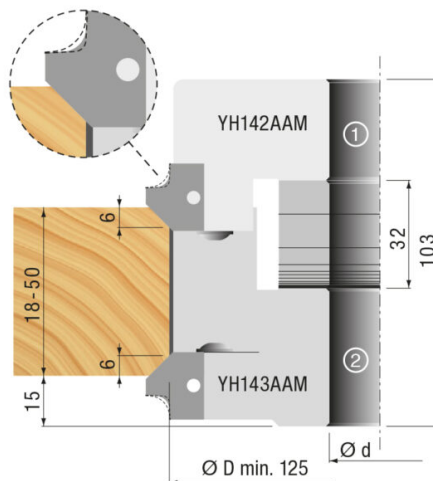
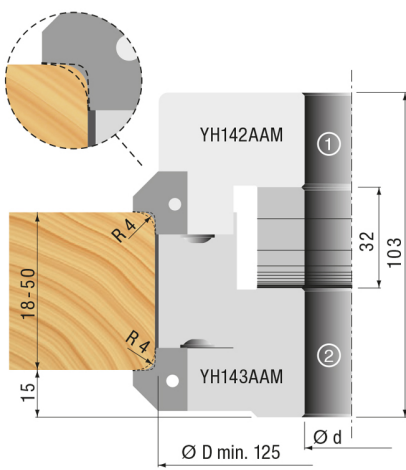

Cutterset consisting of two elements in light alloy with reversible tungsten carbide knives (HW). Cutter set specifically designed to perform both high precision planing and chamfering. Suitable for machining wood with a height between 18mm and 50mm. The blades have a radius on the one hand and a chamfer of 45° on the other hand. The blades with radius R4 are mounted on the milling head as standard. Knives with radius R2, R3, R5 and R6 are available separately.

Because the knives are placed both above and below the cutterset, it is possible to round off/chamfer your workpiece in one passage. Thanks to the tungsten carbide blades, this profile cutter cuts effortlessly through solid boards or solid wood. Also suitable for use on sheet materials.

Available with bore 30mm or 50mm.

### **PRODUCT INFORMATION**

- For spindle moulder machines
- Rounding and bevelling cutter
  - Different radius available
    - Hard and soft wood
  - For MDF or board material

### **DESCRIPTION**

Cutterset consisting of two elements in light alloy with reversible tungsten carbide knives (HW). Cutter set specifically designed to perform both high precision planing and chamfering. Suitable for machining wood with a height between 18mm and 50mm. The blades have a radius on the one hand and a chamfer of 45° on the other hand. The blades with radius R4 are mounted on the milling head as standard. Knives with radius R2, R3, R5 and R6 are available separately. Because the knives are placed both above and below the cutterset, it is possible to round off/chamfer your workpiece in one passage. Thanks to the tungsten carbide blades, this profile cutter cuts effortlessly through solid boards or solid wood. Also suitable for use on sheet materials.

Available with bore 30mm or 50mm.

No video available for this product!

### **DOWNLOADS**

No download available.

## ADDITIONAL INFORMATION

<b>Weight</b>	1 kg
<b>diameter</b>	139mm
<b>Shaft diameter</b>	30 mm, 50 mm
<b>Height of groove</b>	18-50mm
<b>Cutting edges</b>	2+2+2
<b>Radius</b>	R4
<b>Angle</b>	45°
<b>RPM Min-Max</b>	5500-9400